

On Balance Index Sets of Trees of Diameter Four

Sin-Min Lee

Department of Computer Science
San Jose State University
San Jose, CA 95192, USA

Hsin-Hao Su

Department of Mathematics
Stonehill College
Easton, MA 02357, USA

Yung-Chin Wang

Dept. of Physical Therapy
Tzu-Hui Institute of Technology
Taiwan, Republic of China

Abstract

Let G be a simple graph with a vertex set $V(G)$ and an edge set $E(G)$, and let $\mathbb{Z}_2 = \{0, 1\}$. A labeling $f : V(G) \rightarrow \mathbb{Z}_2$ induces an edge partial labeling $f^* : E(G) \rightarrow A$ defined by $f^*(xy) = f(x)$ if and only if $f(x) = f(y)$ for each edge $xy \in E(G)$. For each $i \in \mathbb{Z}_2$, let $v_f(i) = |\{v \in V(G) : f(v) = i\}|$ and $e_f(i) = |\{e \in E(G) : f^*(e) = i\}|$. The balance index set of G , denoted $BI(G)$, is defined as $\{|e_f(0) - e_f(1)| : |v_f(0) - v_f(1)| \leq 1\}$. In this paper, we investigate and present results concerning the balance index sets of trees of diameter four.

1 Introduction

In [12], Lee, Liu and Tan considered a labeling problem in graph theory. Let G be a graph with a vertex set $V(G)$ and an edge set $E(G)$. A vertex labeling of a graph G is a mapping f from $V(G)$ into $\{0, 1\}$. For each vertex labeling f of G , we can define a partial edge labeling f^* of G as follow: for

each edge uv in E , define

$$f^*(uv) = \begin{cases} 0 & \text{if } f(u) = f(v) = 0, \\ 1 & \text{if } f(u) = f(v) = 1. \end{cases}$$

Note that if $f(u) \neq f(v)$, then the edge uv is not labeled by f^* . We shall refer f^* as the **induced partial function** of f . For $i = 0, 1$, let $v_f(i)$ denote the number of vertices of G that are labeled by i under the mapping f . Similarly, let $e_f(i)$ denote the numbers of edges of G that are labeled by i under the induced partial function f^* . In other words, for $i = 0, 1$,

$$\begin{aligned} v_f(i) &= |\{u \in V(G) : f(u) = i\}|, \text{ and,} \\ e_f(i) &= |\{uv \in E(G) : f^*(uv) = i\}|. \end{aligned}$$

For brevity, when the context is clear, we will simply write $v(0)$, $v(1)$, $e(0)$ and $e(1)$ without any subscript.

Definition 1. A vertex labeling f of a graph G is said to be **friendly** if $|v_f(0) - v_f(1)| \leq 1$, and **balanced** if both $|v_f(0) - v_f(1)| \leq 1$ and $|e_f(0) - e_f(1)| \leq 1$.

It is clear that not all the friendly graphs are balanced.

In [10], A.N.T. Lee, Lee and Ng introduced the following notion as an extension of their study of the balanced graphs.

Definition 2. The **balance index set** of a graph G is defined as

$$\text{BI}(G) = \{|e_f(0) - e_f(1)| : \text{the vertex labeling } f \text{ is friendly}\}.$$

Example 1. Figure 1 shows a graph G with $\text{BI}(G) = \{0, 1, 2\}$. □

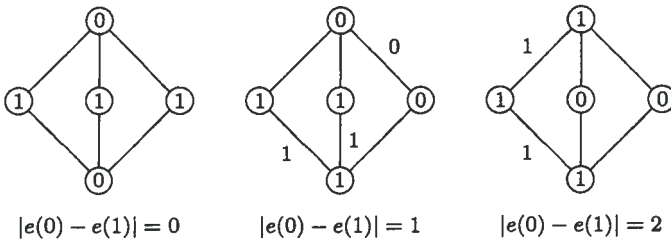

Figure 1: The friendly labelings of a graph G with $\text{BI}(G) = \{0, 1, 2\}$.

In [15], Lee, Wang and Wen found the balance index set of cycles.

Proposition 1.1. Let $\bigcup_{i=1}^k C_{n_i}^i$ be a finite disjoint union of k cycles, where $C_{n_i}^i$ is the cycle of order n_i for all $1 \leq i \leq k$. The balance index set is

$$BI\left(\bigcup_{i=1}^k C_{n_i}^i\right) = \begin{cases} \{0\} & \text{if } \sum n_i \text{ is even, and,} \\ \{1\} & \text{if } \sum n_i \text{ is odd.} \end{cases}$$

We note here that not every graph has a balance index set consisting of an arithmetic progression.

Example 2. The graph $\Phi(1, 3, 1, 1)$ is composed of $C_4(3)$ with a pendant edge appended to each of x_1, x_3 and x_4 , and three pendant edges appended to x_2 . Figure 2 shows that $BI(\Phi(1, 3, 1, 1)) = \{0, 1, 2, 3, 4, 6\}$. Note that 5 is missing from the balance index set. \square

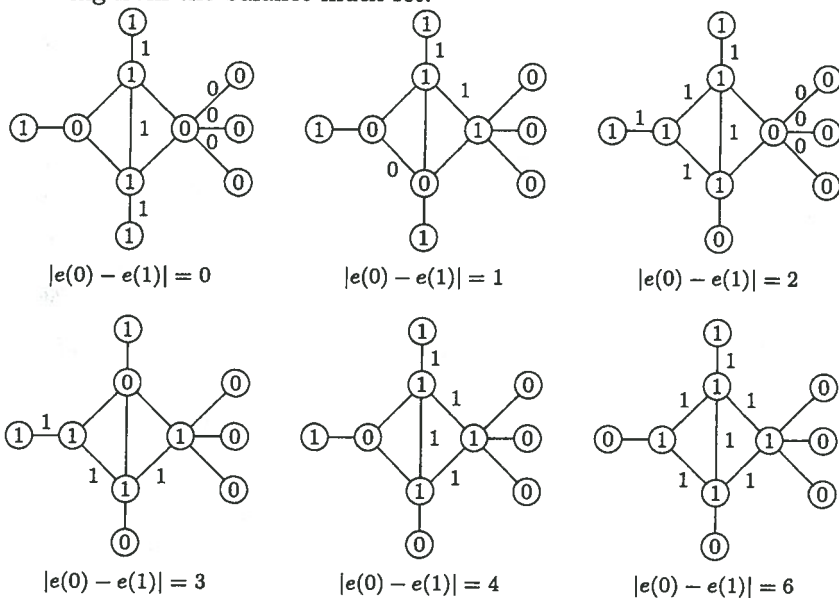
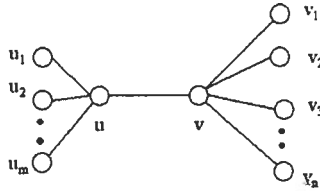

Figure 2: The six friendly labelings of $\Phi(1, 3, 1, 1)$.

Some balanced graphs are considered in [3, 4, 5, 8, 12, 16]. In general, it is difficult to determine the balance index set of a given graph. Most of existing research on this problem have focused on some special families of graphs with simple structures, see [1, 6, 7, 10, 13, 14, 15].

The double star $DS(m, n)$ is a tree of diameter three such that there are m pendant edges on one end of P_2 and n pendant edges on the other end.



Without loss of generality, we may assume $m \leq n$.

From [10], we recall the following

Proposition 1.2. *The balance index set of the double star $DS(m, n)$, where $m \leq n$, is*

$$BI(DS(m, n)) = \begin{cases} \left\{ \frac{n-m}{2}, \frac{n+m}{2} \right\} & \text{if } m+n \text{ is even, or,} \\ \left\{ \frac{n-m-1}{2}, \frac{n-m+1}{2}, \frac{n+m-1}{2}, \frac{n+m+1}{2} \right\} & \text{if } m+n \text{ is odd.} \end{cases}$$

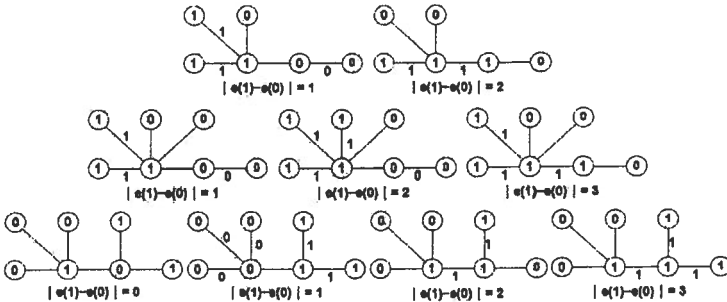

Figure 3: $BI(DS(1, 3))$, $BI(DS(1, 4))$ and $BI(DS(2, 3))$

The balance index sets of the graph which are formed by the amalgamation of complete graphs, stars, and generalized theta graphs are studied in [6, 7]. In this paper, we complete the study of the balance index sets of trees of diameter four.

2 Balance Index Set of Caterpillar $CT(a, b, c)$

For a graph with a vertex labeling f , we denote $e_f(x)$ to be the subset of $E(G)$ containing all the unlabeled edges.

We say f is friendly if $|v(0) - v(1)| \leq 1$.

In [9], Kwong and Shiu developed an algebraic approach to attack the balance index set problems. It shows that the balance index set depends

on the degree sequence of the graph. It becomes a very powerful tool to deal with balance indexes.

Here we twist their approach a little bit and propose our version here:

Lemma 2.1. *We have the following equalities:*

1. $2e(0) + e(\times) = \sum_{v \in v(0)} \deg v;$
2. $2e(1) + e(\times) = \sum_{v \in v(1)} \deg v;$
3. $2|E(G)| = \sum_{v \in V(G)} \deg v = \sum_{v \in v(0)} \deg v + \sum_{v \in v(1)} \deg v.$

Proof. Each unlabeled edge contains one 0-vertex, and each 0-edge contributes two 0-vertices. For a vertex labeled 0, there are $\deg(v)$ edges adjacent to it. Equation 1 follows. Similarly, we can prove Equation 2. Since $\deg(v)$ represents the number of edges adjacent to v and each edge is adjacent to two vertices, the sum of all degrees is twice of the number of edges of G . \square

Corollary 2.2. *For any friendly vertex labeling f , the balance index is*

$$e(0) - e(1) = \frac{1}{2} \left(\sum_{v \in v(0)} \deg v - \sum_{v \in v(1)} \deg v \right).$$

For a caterpillar graph $CT(a, b, c)$, we name the three vertices on the spine, u_a , u_b , and u_c . Thus, in $CT(a, b, c)$, we have $a+b+c$ degree 1 vertices. The degrees of u_a , u_b , and u_c are $a+1$, $b+2$, and $c+1$, respectively. We also name the non-spinal vertices adjacent to u_b by $u_{b,1}, u_{b,2}, \dots, u_{b,b}$. Similarly, we name non-spinal vertices adjacent to u_a or u_c by the same way.

Theorem 2.3. *For $CT(a, b, c)$, where $a + b + c$ is odd, the balance index set is*

$$\left\{ \left| \frac{a+b+c+1}{2} \right|, \left| \frac{a+b-c+1}{2} \right|, \left| \frac{a-b+c-1}{2} \right|, \left| \frac{a-b-c-1}{2} \right| \right\}.$$

Proof. When $a+b+c$ is odd, the number of vertices of $CT(a, b, c)$ is equal to $a+b+c+3$ which is even. Let $a+b+c+3 = 2M$. For a friendly labeling, there are M vertices labeled 0 and M vertices labeled 1.

We first consider the case that $u_a, u_b,$ and u_c are all labeled 0. Then there are $M - 3$ end-vertices labeled 0 and M end-vertices labeled 1. By Corollary 2.2, we have

$$\begin{aligned} e(0) - e(1) &= \frac{1}{2} \left(\sum_{v \in v(0)} \deg v - \sum_{v \in v(1)} \deg v \right) \\ &= \frac{1}{2} [(M - 3) + (a + 1) + (b + 2) + (c + 1) - M] \\ &= \frac{1}{2} (a + b + c + 1) \end{aligned}$$

There are 8 different combinations of the labeling of $u_a, u_b,$ and u_c . Each labeling produces a balance index by the similar way. We collect all of them in the following table:

$f(u_a)$	$f(u_b)$	$f(u_c)$	No. of deg 1 0-v	No. of deg 1 1-v	BI
0	0	0	$M - 3$	M	$\frac{a+b+c+1}{2}$
0	0	1	$M - 2$	$M - 1$	$\frac{a+b-c+1}{2}$
0	1	0	$M - 2$	$M - 1$	$\frac{a-b+c-1}{2}$
0	1	1	$M - 1$	$M - 2$	$\frac{a-b-c-1}{2}$
1	0	0	$M - 2$	$M - 1$	$\frac{-a+b+c+1}{2}$
1	0	1	$M - 1$	$M - 2$	$\frac{-a+b-c+1}{2}$
1	1	0	$M - 1$	$M - 2$	$\frac{-a-b+c+1}{2}$
1	1	1	M	$M - 3$	$\frac{-a-b-c-1}{2}$

Figure 4: 8 different combinations of the labeling of $u_a, u_b,$ and u_c when $a + b + c$ is even

Thus, the set of balance indexes is $\left\{ \frac{a+b+c+1}{2}, \frac{a+b-c+1}{2}, \frac{a-b+c-1}{2}, \frac{a-b-c-1}{2}, \frac{-a+b+c+1}{2}, \frac{-a+b-c+1}{2}, \frac{-a-b+c+1}{2}, \frac{-a-b-c-1}{2} \right\}$. Note that the last four indexes are the negative of the first four indexes. Therefore,

$$\text{BI} = \left\{ \left| \frac{a+b+c+1}{2} \right|, \left| \frac{a+b-c+1}{2} \right|, \left| \frac{a-b+c-1}{2} \right|, \left| \frac{a-b-c-1}{2} \right| \right\}.$$

□

Theorem 2.4. For $CT(a, b, c)$, where $a + b + c$ is even, the balance index set is

$$\begin{aligned} &\left\{ \left| \frac{a+b+c+2}{2} \right|, \left| \frac{a+b-c+2}{2} \right|, \left| \frac{a-b+c}{2} \right|, \left| \frac{a-b-c}{2} \right|, \right. \\ &\left. \left| \frac{-a+b+c+2}{2} \right|, \left| \frac{-a+b-c+2}{2} \right|, \left| \frac{-a-b+c}{2} \right|, \left| \frac{-a-b-c}{2} \right| \right\}. \end{aligned}$$

Proof. When $a+b+c$ is even, the number of vertices of $CT(a, b, c)$ is equal to $a+b+c+3$ which is odd. Let $a+b+c+3 = 2M+1$. For a friendly labeling, without loss of generality, there are $M+1$ vertices labeled 0 and M vertices labeled 1.

We first consider the case that $u_a, u_b,$ and u_c are all labeled 0. Then there are $M-2$ end-vertices labeled 0 and M end-vertices labeled 1. By Corollary 2.2, we have

$$\begin{aligned} e(0) - e(1) &= \frac{1}{2} \left(\sum_{v \in v(0)} \deg v - \sum_{v \in v(1)} \deg v \right) \\ &= \frac{1}{2} [(M-2) + (a+1) + (b+2) + (c+1) - M] \\ &= \frac{1}{2} (a+b+c+2) \end{aligned}$$

There are 8 different combinations of the labeling of $u_a, u_b,$ and u_c . Each labeling produces a balance index by the similar way. We collect all of them in the following table:

$f(u_a)$	$f(u_b)$	$f(u_c)$	No. of deg 1 0-v	No. of deg 1 1-v	BI
0	0	0	$M-2$	M	$\frac{a+b+c+2}{2}$
0	0	1	$M-1$	$M-1$	$\frac{a+b-c+2}{2}$
0	1	0	$M-1$	$M-1$	$\frac{a-b+c}{2}$
0	1	1	M	$M-2$	$\frac{a-b-c}{2}$
1	0	0	$M-1$	$M-1$	$\frac{-a+b+c+2}{2}$
1	0	1	M	$M-2$	$\frac{-a+b-c+2}{2}$
1	1	0	M	$M-2$	$\frac{-a-b+c}{2}$
1	1	1	$M+1$	$M-3$	$\frac{-a-b-c}{2}$

Figure 5: 8 different combinations of the labeling of $u_a, u_b,$ and u_c when $a+b+c$ is odd

When a friendly labeling with $v(1) > v(0)$, it produces the negative values of all the above balance indexes. By combining all 16 balance indexes together, they are $\frac{a+b+c+2}{2}, \frac{a+b-c+2}{2}, \frac{a-b+c}{2}, \frac{a-b-c}{2}, \frac{-a+b+c+2}{2}, \frac{-a+b-c+2}{2}, \frac{-a-b+c}{2}, \frac{-a-b-c}{2}, \frac{-a+b+c+2}{2}, \frac{-a+b-c+2}{2}, \frac{-a-b+c}{2}, \frac{-a-b-c}{2}, \frac{-a+b+c+2}{2}, \frac{-a+b-c+2}{2}, \frac{-a-b+c}{2}, \frac{-a-b-c}{2}$. After taking absolute value, we have only 8 balance indexes left due to the sign difference. Therefore, the balance index set is

$$\begin{aligned} BI = & \left\{ \left| \frac{a+b+c+2}{2} \right|, \left| \frac{a+b-c+2}{2} \right|, \left| \frac{a-b+c}{2} \right|, \left| \frac{a-b-c}{2} \right|, \right. \\ & \left. \left| \frac{-a+b+c+2}{2} \right|, \left| \frac{-a+b-c+2}{2} \right|, \left| \frac{-a-b+c}{2} \right|, \left| \frac{-a-b-c}{2} \right| \right\}. \end{aligned}$$

Example 3. Figure 6 shows the caterpillar $CT(1, 1, 3)$ with 8 vertices has balance index set $\{0, 1, 2, 3\}$.

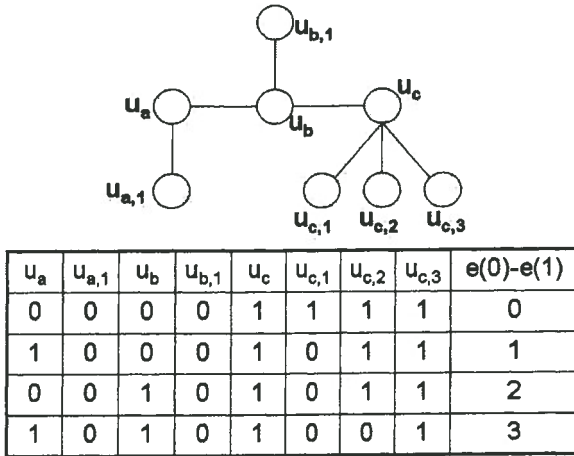

Figure 6: The balance index set of $CT(1, 1, 3)$

Example 4. Figure 7 shows the caterpillar $CT(3, 0, 3)$ with 9 vertices has balance index set $\{0, 1, 2, 3, 4\}$.

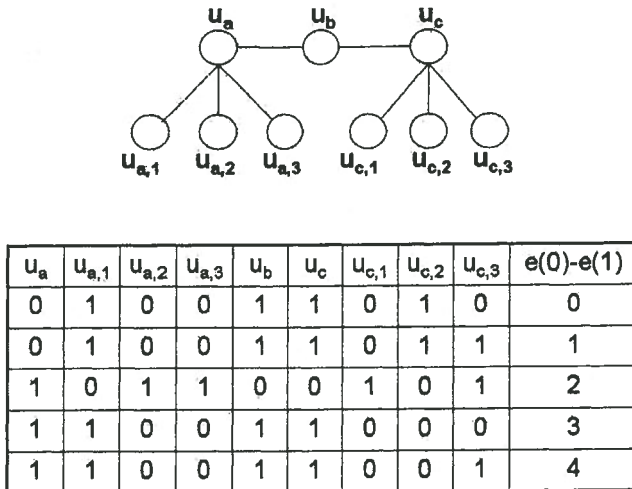

Figure 7: The balance index set of $CT(3, 0, 3)$

Here we use Theorem 2.3 to prove a special case.

Corollary 2.5. *The balance index set of $CT(a, 1, a)$ is*

$$\{a + 1, a - 1, 1\}.$$

Proof. By Theorem 2.3, since $a + 1 + a = 2a + 1$ is always odd, the balance index set is

$$\left\{ \left| \frac{a + 1 + a + 1}{2} \right|, \left| \frac{a + 1 - a + 1}{2} \right|, \left| \frac{a - 1 + a - 1}{2} \right|, \left| \frac{a - 1 - a - 1}{2} \right| \right\},$$

i.e.,

$$\{a + 1, 1, a - 1\}.$$

□

Example 5. Figure 8 shows $BI(CT(2, 1, 2)) = \{1, 3\}$, $BI(CT(3, 1, 3)) = \{4, 2, 1\}$ and $BI(CT(5, 1, 5)) = \{6, 4, 1\}$.

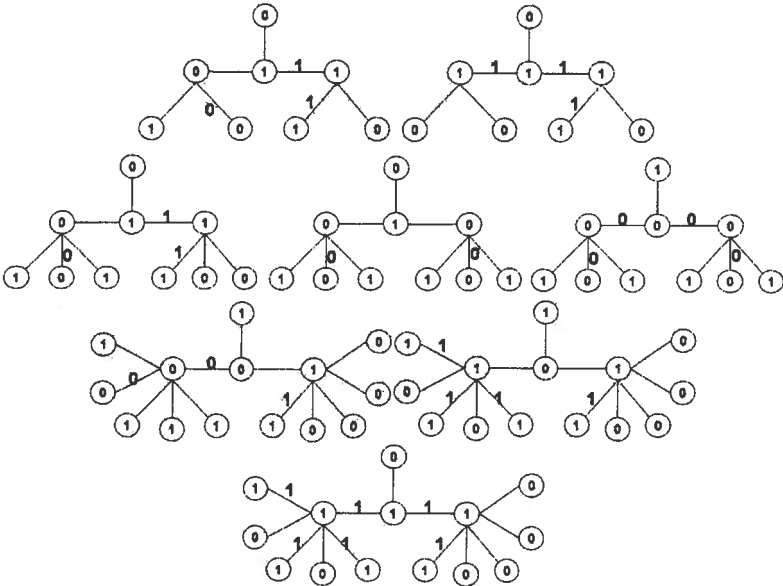

Figure 8: The balance index sets of $CT(2, 1, 2)$, $CT(3, 1, 3)$ and $CT(5, 1, 5)$

The balance index sets depend on the topological structure of the graphs. In the following example, we demonstrate two graphs of the same order but with different balance index sets.

Example 6. Figure 9 shows the caterpillar T_1 with 10 vertices has balance index set $\{1, 2, 4\}$. However, another caterpillar T_2 also has order 10 but its balance index set is $\{0, 2, 4\}$. \square

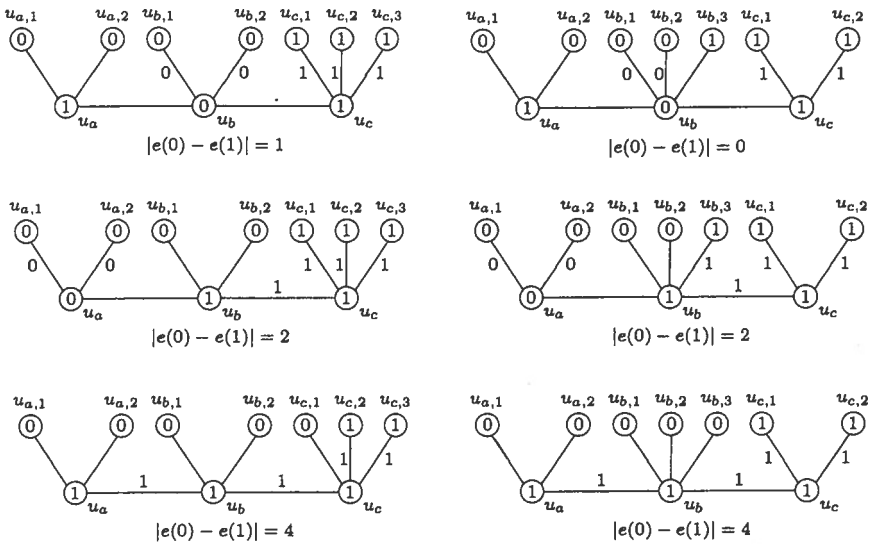

Figure 9: The balance index sets of $P_3 \times_L \Phi$.

3 Balance Index Sets of Trees of Diameter Four

In a caterpillar graph $CT(a, b, c)$, if $b \neq 0$, then we have $b P_3$ paths contained the vertex u_b . Since P_3 is of length 2, after adding more adjacent edges and vertices to the two end vertices of these paths, the new graph is still a tree of diameter four. We denote this new graph as $CT(a, b, c)(u_b(t_1, t_2, \dots, t_b))$, where t_i is the number of edges and vertices added to the vertex $u_{b,i}$.

It is easy to see that a tree of diameter four can be expressed as $CT(a, b, c)(u_b(t_1, t_2, \dots, t_b))$ for some a, b, c and t_i for all $1 \leq i \leq b$.

In order to write our final results in an uniform manner, we rename $CT(a, b, c)(u_b(t_1, t_2, \dots, t_b))$ as $CT(d_1, d_0, d_2)(u_b(d_3, d_4, \dots, d_{d_0+2}))$. In the other words, we define $d_1 = a$, $d_0 = b$, $d_2 = c$, and $d_i = t_{i-2}$ when $3 \leq i \leq b$.

By the same reason, we also rename the three vertices on the spine, v_0 , v_1 , and v_2 where v_0 is the middle one. We also name the vertices adjacent to v_0 by $v_3, v_4, \dots, v_{d_0+2}$. Thus, in $CT(d_1, d_0, d_2)(u_b(d_3, d_4, \dots, d_{d_0+2}))$, we have $\sum_{i=0}^{d_0+2} d_i$ degree 1 vertices. The degree of v_i for all $1 \leq i \leq d_0 + 2$ is $d_i + 1$, and, the degree of v_0 is $d_0 + 2$.

Theorem 3.1. For $CT(d_1, d_0, d_2)(u_b(d_3, d_4, \dots, d_{d_0+2}))$, where $\sum_{i=0}^{d_0+2} d_i$ is odd, for a friendly labeling f , the balance index is

$$e(0) - e(1) = \frac{1}{2} \left\{ \left[\sum_{i=0}^{d_0+2} (-1)^{f(v_i)} d_i \right] + (-1)^{f(v_0)} \right\}.$$

Proof. The number of vertices of $CT(d_1, d_0, d_2)(u_b(d_3, d_4, \dots, d_{d_0+2}))$ is equal to $\sum_{i=0}^{d_0+2} d_i + 3$ which is even if $\sum_{i=0}^{d_0+2} d_i$ is odd. Let $\sum_{i=0}^{d_0+2} d_i + 3 = 2M$. For a friendly labeling, there are M vertices labeled 0 and M vertices labeled 1.

We first consider the case that v_i for all $1 \leq i$ are all labeled 0. Then there are $M - 3 - d_0$ end-vertices labeled 0 and M end-vertices labeled 1. By Corollary 2.2, we have

$$\begin{aligned} e(0) - e(1) &= \frac{1}{2} \left(\sum_{v \in v(0)} \deg v - \sum_{v \in v(1)} \deg v \right) \\ &= \frac{1}{2} \left[(M - 3 - d_0) + (d_0 + 2) + \sum_{i=1}^{d_0+2} (d_i + 1) - M \right] \\ &= \frac{1}{2} \left[\left(\sum_{i=0}^{d_0+2} d_i \right) + 1 \right] \end{aligned}$$

Similarly, we assume that there are k vertices among v_i for all $0 \leq i \leq d_0 + 2$ labeled 0. Then, there are $M - k$ end-vertices labeled 0 and $M - (d_0 + 3 - k)$ end-vertices labeled 1. We define P to be the set containing all the 0-vertices among v_i for all $0 \leq i \leq d_0 + 2$. We also define N to be the set containing all the 1-vertices among v_i for all $0 \leq i \leq d_0 + 2$. By Corollary 2.2, we have

$$\begin{aligned}
& e(0) - e(1) \\
&= \frac{1}{2} \left(\sum_{v \in v(0)} \deg v - \sum_{v \in v(1)} \deg v \right) \\
&= \frac{1}{2} \left[\left((M - k) + \sum_{v \in P} \deg v \right) - \left((M - (d_0 + 3 - k) + \sum_{v \in N} \deg v) \right) \right] \\
&= \frac{1}{2} \left[(M - k) - (M - (d_0 + 3 - k)) + \sum_{v \in P} [(\deg v - 1) + 1] \right. \\
&\quad \left. - \sum_{v \in N} [(\deg v - 1) + 1] \right] \\
&= \frac{1}{2} \left[(d_0 + 3 - 2k) + \sum_{v \in P} (\deg v - 1) + k - \sum_{v \in N} (\deg v - 1) \right. \\
&\quad \left. - (d_0 + 3 - k) \right] \\
&= \frac{1}{2} \left[\sum_{v \in P} (\deg v - 1) - \sum_{v \in N} (\deg v - 1) \right]
\end{aligned}$$

Note here that $\deg(v_i) - 1 = d_i$ for all $0 \leq i \leq d_0 + 2$. $\deg(v_0) - 1 = d_0 + 1$. For a friendly labeling f , we have

$$e(0) - e(1) = \frac{1}{2} \left\{ \left[\sum_{i=0}^{d_0+2} (-1)^{f(v_i)} d_i \right] + (-1)^{f(v_0)} \right\}.$$

□

From the result of Theorem 3.1, it is obviously that when all labeling of v_i for all $0 \leq i \leq d_0 + 2$ change signs, $e(0) - e(1)$ changes sign too. Thus, without missing any balance index, we can assume that v_0 is labeled 0. This leads to

Corollary 3.2. For $CT(d_1, d_0, d_2)(u_b(d_3, d_4, \dots, d_{d_0+2}))$, where $\sum_{i=0}^{d_0+2} d_i$ is odd, for a friendly labeling f , the balance index is

$$|e(0) - e(1)| = \left| \frac{1}{2} \left\{ \left[\sum_{i=0}^{d_0+2} (-1)^{f(v_i)} d_i \right] + d_0 + 1 \right\} \right|.$$

Let SC be the set of

$$SC = \left\{ \sum_{i=1}^{d_0+2} (-1)^{t_i} d_i \mid t_i = 0, 1 \right\}.$$

We can simplify Corollary 3.2 into

Corollary 3.3. For $CT(d_1, d_0, d_2)(u_b(d_3, d_4, \dots, d_{d_0+2}))$, where $\sum_{i=0}^{d_0+2} d_i$ is odd, the balance index is

$$\left\{ \left\lfloor \frac{1}{2} (t + d_0 + 1) \right\rfloor \mid t \in SC \right\}.$$

Theorem 3.4. For $CT(d_1, d_0, d_2)(u_b(d_3, d_4, \dots, d_{d_0+2}))$, where $\sum_{i=0}^{d_0+2} d_i$ is even, for a friendly labeling f , the balance index is

$$e(0) - e(1) = \pm \frac{1}{2} \left\{ \left[\sum_{i=0}^{d_0+2} (-1)^{f(v_i)} d_i \right] + 1 + (-1)^{f(v_0)} \right\}.$$

Proof. The number of vertices of $CT(d_1, d_0, d_2)(u_b(d_3, d_4, \dots, d_{d_0+2}))$ is equal to $\sum_{i=0}^{d_0+2} d_i + 3$ which is odd ifn $\sum_{i=0}^{d_0+2} d_i$ is even. Let $\sum_{i=0}^{d_0+2} d_i + 3 = 2M + 1$. For a friendly labeling, there are $M + 1$ vertices labeled 0 and M vertices labeled 1.

We first consider the case that v_i for all $1 \leq i$ are all labeled 0. Then there are $(M + 1) - 3 - d_0$ end-vertices labeled 0 and M end-vertices labeled 1. By Corollary 2.2, we have

$$\begin{aligned} e(0) - e(1) &= \frac{1}{2} \left(\sum_{v \in v(0)} \deg v - \sum_{v \in v(1)} \deg v \right) \\ &= \frac{1}{2} \left[(M + 1 - 3 - d_0) + (d_0 + 2) + \sum_{i=1}^{d_0+2} (d_i + 1) - M \right] \\ &= \frac{1}{2} \left[\left(\sum_{i=0}^{d_0+2} d_i \right) + 2 \right] \end{aligned}$$

Similarly, we assume that there are k vertices among v_i for all $0 \leq i \leq d_0 + 2$ labeled 0. Then, there are $M + 1 - k$ end-vertices labeled 0 and $M - (d_0 + 3 - k)$ end-vertices labeled 1. We define P to be the set containing all the 0-vertices among v_i for all $0 \leq i \leq d_0 + 2$. We also define N to be the set containing all the 1-vertices among v_i for all $0 \leq i \leq d_0 + 2$. By Corollary 2.2, we have

$$\begin{aligned}
& e(0) - e(1) \\
&= \frac{1}{2} \left(\sum_{v \in v(0)} \deg v - \sum_{v \in v(1)} \deg v \right) \\
&= \frac{1}{2} \left[\left((M+1-k) + \sum_{v \in P} \deg v \right) - \left((M - (d_0 + 3 - k) + \sum_{v \in N} \deg v) \right) \right] \\
&= \frac{1}{2} \left[(M+1-k) - (M - (d_0 + 3 - k) + \sum_{v \in P} [(\deg v - 1) + 1] \right. \\
&\quad \left. - \sum_{v \in N} [(\deg v - 1) + 1] \right) \\
&= \frac{1}{2} \left[1 + (d_0 + 3 - 2k) + \sum_{v \in P} (\deg v - 1) + k - \sum_{v \in N} (\deg v - 1) \right. \\
&\quad \left. - (d_0 + 3 - k) \right] \\
&= \frac{1}{2} \left[1 + \sum_{v \in P} (\deg v - 1) - \sum_{v \in N} (\deg v - 1) \right]
\end{aligned}$$

Note here that $\deg(v_i) - 1 = d_i$ for all $0 \leq i \leq d_0 + 2$. $\deg(v_0) - 1 = d_0 + 1$. For a friendly labeling f , we have

$$e(0) - e(1) = \frac{1}{2} \left\{ \left[\sum_{i=0}^{d_0+2} (-1)^{f(v_i)} d_i \right] + 1 + (-1)^{f(v_0)} \right\}.$$

When a friendly labeling with $v(1) > v(0)$, it produces the negative values of all the above balance indexes. This completes the proof. \square

Recall that SC is the set of

$$SC = \left\{ \sum_{i=1}^{d_0+2} (-1)^{t_i} d_i \mid t_i = 0, 1 \right\}.$$

Corollary 3.5. For $CT(d_1, d_0, d_2)(u_b(d_3, d_4, \dots, d_{d_0+2}))$, where $\sum_{i=0}^{d_0+2} d_i$ is even, the balance index is

$$\left\{ \left\lfloor \frac{1}{2} (t + d_0 + 1) \right\rfloor \mid t \in SC \right\} \cup \left\{ \left\lfloor \frac{1}{2} (t + d_0) \right\rfloor \mid t \in SC \right\}.$$

Proof. For a set of labelings of v_i for all $0 \leq i \leq d_0 + 2$, name the balance index of this set OBI . From the result of Theorem 3.4, we know that

$$OBI = \pm \frac{1}{2} \left\{ \left[\sum_{i=0}^{d_0+2} (-1)^{f(v_i)} d_i \right] + 1 + (-1)^{f(v_0)} \right\}.$$

If all labelings change signs, the new balance index $e(0) - e(1)$ is

$$\begin{aligned} e(0) - e(1) &= \pm \frac{1}{2} \left\{ \left[\sum_{i=0}^{d_0+2} (-1)^{f(v_i)+1} d_i \right] + 1 + (-1)^{f(v_0)+1} \right\} \\ &= \mp \frac{1}{2} \left\{ \left[\sum_{i=0}^{d_0+2} (-1)^{f(v_i)} d_i \right] - 1 + (-1)^{f(v_0)} \right\} \\ &= \mp \frac{1}{2} \left\{ \left[\sum_{i=0}^{d_0+2} (-1)^{f(v_i)} d_i \right] + 1 + (-1)^{f(v_0)} \right\} + 1 \\ &= -OBI + 1 \end{aligned}$$

which depends on OBI .

If we assume that v_0 is labeled 0, then, the balance index is

$$e(0) - e(1) = \pm \frac{1}{2} \left\{ \left[\sum_{i=1}^{d_0+2} (-1)^{f(v_i)} d_i \right] + 1 + (-1)^0 \right\}.$$

The balance index with v_0 is labeled 1 can be obtained by $1 - OBI$ where OBI is any balance index obtained by assuming v_0 is labeled 0. Note that

$$\begin{aligned} 1 - OBI &= 1 - \frac{1}{2} \left\{ \left[\sum_{i=1}^{d_0+2} (-1)^{f(v_i)} d_i \right] + d_0 + 1 + (-1)^0 \right\} \\ &= -\frac{1}{2} \left\{ \left[\sum_{i=1}^{d_0+2} (-1)^{f(v_i)} d_i \right] + d_0 \right\}. \end{aligned}$$

This completes the proof. □

Example 7. For $CT(1, 3, 2)(u_b(0, 0, 3))$, first, we can see that $SC = \{6, 0, 2, -4, 4, -2, 0, -6\}$. Since $1 + 3 + 2 + 3 = 9$ is odd, by Corollary 3.3, we compute $3 + 1 + SC = \{10, 4, 6, 0, 8, 2, 4, -2\}$. Thus, the BI collection is $\{5, 2, 3, 0, 4, 1, 2, -1\}$. By taking absolute value, the result follows. Figure 10 shows the balance index set of $CT(1, 3, 2)(u_b(0, 0, 3))$ is $\{0, 1, 2, 3, 4, 5\}$.

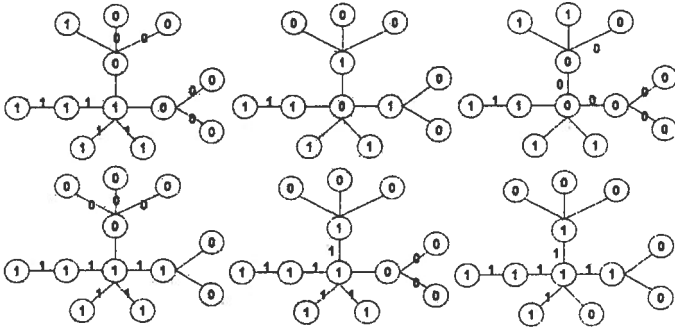

Figure 10: Balance index set of $CT(1, 3, 2)(u_b(0, 0, 3))$

Example 8. For $CT(1, 3, 2)(u_b(0, 0, 4))$, first, we can see that $SC = \{7, -1, 3, -5, 5, -3, -1, -7\}$. Since $1 + 3 + 2 + 4 = 10$ is even, by Corollary 3.5, we compute $3 + SC = \{5, 1, 3, -1, 4, 0, 1, -2\}$. Thus, we have $(3 + SC) + 1 = \{6, 2, 4, 0, 5, 1, 2, -1\}$. By taking absolute value and union, the result follows. Figure 11 shows the balance index set of $CT(1, 3, 2)(u_b(0, 0, 3))$ is $\{0, 1, 2, 3, 4, 5, 6\}$.

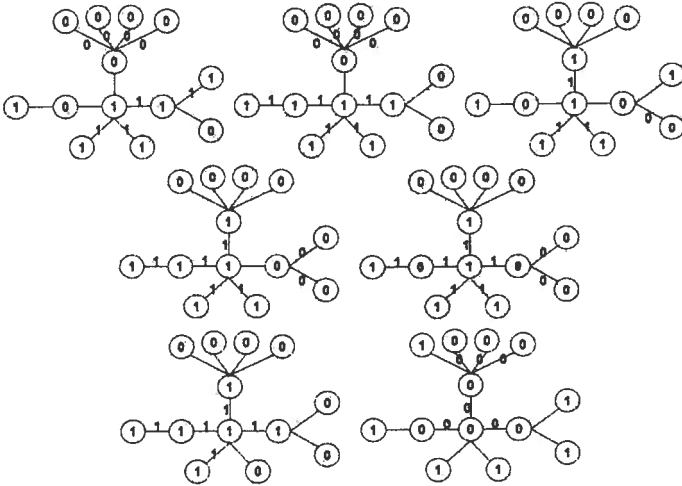

Figure 11: Balance index set of $CT(1, 3, 2)(u_b(0, 0, 4))$

By Corollaries 3.3 and 3.5 and Examples 8 and 9, we need to calculate all values in the set SC in order to find the balance index set of $CT(d_1, d_0, d_2)(u_b(d_3, d_4, \dots, d_{d_0+2}))$. It is very easy to find the numerical result by using a computer program. Here, we show one more example

in detail.

Example 9. For $CT(2, 4, 2)(u_b(0, 0, 0, 3))$, first, we can see that $SC = \{7, 1, 3, -3, 3, -3, -1, -7\}$. Since $2 + 4 + 2 + 3 = 11$ is odd, by Corollary 3.3, we compute $4 + 1 + SC = \{12, 6, 8, 2, 8, 2, 4, -2\}$. Thus, the BI collection is $\{6, 3, 4, 1, 4, 1, 2, -1\}$. By taking absolute value, the result follows. Figure 12 shows the balance index set of $CT(1, 3, 2)(u_b(0, 0, 3))$ is $\{1, 2, 3, 4, 6\}$. Note 0 and 5 are missing.

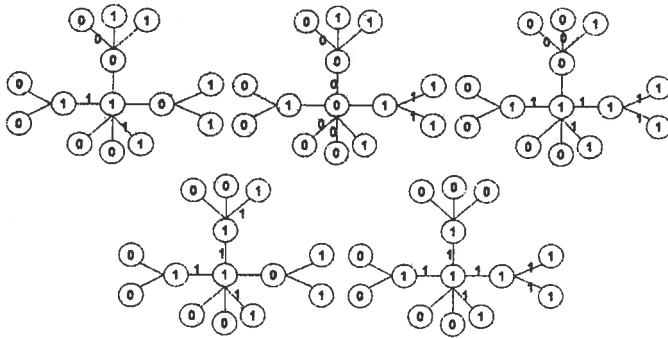

Figure 12: Balance index set of $CT(2, 4, 2)(u_b(0, 0, 0, 3))$

References

- [1] C.C. Chou and S.M. Lee, On the balance index sets of the amalgamation of complete graphs and stars, manuscript.
- [2] F. Harary, *Graph Theory*, Reading, MA, Addison-Wesley, 1994.
- [3] Y.S. Ho, S.M. Lee, H.K. Ng and Y.H. Wen, On Balancedness of Some Families of Trees, to appear in *J. Combin. Math. Combin. Comput.*
- [4] R.Y. Kim, S.M. Lee and H.K. Ng, On balancedness of some graph construction, *J. Combin. Math. Combin. Comput.*, **66** (2008), 3-16.
- [5] Man C. Kong, S.M. Lee, Eric Seah and Alfred S. Tang, A complete characterization of balanced graphs, *J. Combin. Math. Combin. Comput.*, **66** (2008), 225-236.
- [6] H. Kwong and S.M. Lee, On balance index sets of chain sum and amalgamation of generalized theta graphs, *Congr. Numer.*, **187** (2007), 21-32.

- [7] H. Kwong, S.M. Lee and D.G. Sarvate, On balance index sets of one-point unions of graphs, *J. Combin. Math. Combin. Comput.*, **66** (2008), 113-127.
- [8] H. Kwong, S.M. Lee, Bill Lo and Y.C. Wang, On uniformly balanced graphs, manuscript.
- [9] H. Kwong and W.C. Shiu, An algebraic approach for finding balance index sets, *Australas. J. Combin.*, **45** (2009), 139-155.
- [10] A.N.T. Lee, S.M. Lee and H.K. Ng, On balance index sets of graphs, *J. Combin. Math. Combin. Comput.*, **66** (2008), 135-150.
- [11] A. Lee, S.M. Lee and H.H. Su, On the balance index set of generalized friendship graphs, envelope graphs of cycles and cubic trees, to appear at *Congr. Numer.*
- [12] S.M. Lee, A. Liu and S.K. Tan, On balanced graphs, *Congr. Numer.*, **87** (1992), 59-64.
- [13] S.M. Lee, H.K. Ng and S.M. Tong, On the balance index set of the chain-sum graphs of cycles, *Utilitas Math.*, **77** (2008), 113-123.
- [14] S.M. Lee and H.H. Su, On the balance index set of the permutation graphs, manuscript.
- [15] S.M. Lee, Y.C. Wang and Y.H. Wen, On the balance index sets of the $(p, p+1)$ -graphs, *J. Combin. Math. Combin. Comput.*, **62** (2007), 193-216.
- [16] M.A. Seoud and A.E.I. Abdel Maqsood, On cordial and balanced labelings of graphs, *J. Egyptian Math. Soc.*, **7** (1999) 127-135.