

# CS 185C - Fall 2008

Monday, Wednesday 1:30 to 2:45 P.M.

## Embedded Programming in C

### Course goals:

- Understanding the small embedded environment.
- C language techniques for embedded issues.
- Embedded firmware design.

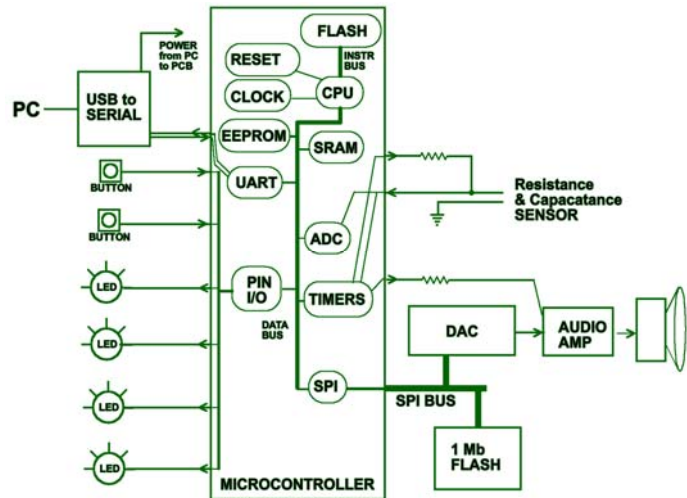

- Students will work on embedded programs in class using laptop PC and Microcontroller P.C. Board. (\$50 cost)
- Practical examples of topics related to CS 47, CS 120I, CS 146, CS 147 and CS 149

### Also covered:

- Architecture of low cost microcontrollers.
- Review of relevant computer architecture details.
- Use and control of common on-chip peripherals.
- Review of important features of C language.
- How and when to use inline Assembly language.
- Use of GNU (Free Open Source) Cross Compiler and Tools.
- Using C++ style organization in C.
- Debugging Techniques.

### C Topics & Code

Memory Mapped Registers  
Interrupt Handlers  
Concurrency - Atomic operations  
Pointers in Detail  
Character I/O  
Stack Overflow  
Array Bounds Overflow  
Event Time Capture  
PWM for Sound Generation  
Analog Sound Generation  
Real time Event Manager  
Multithreading, Task Scheduling  
Preemptive Multithreading

### Processor Architecture

Comparison to more Complex Processors  
Data Representation  
- Endian & Word Size Issues  
- Signed/Unsigned Techniques  
Separate Memory Spaces  
Registers and CPU Context  
Stack Use Details  
Interrupts  
- Hardware support  
- C Interrupt Handler  
- Assembly lang. Handler

### Peripherals on chip

Pin I/O  
- Input or Output  
Timer/Counters, PWM  
- Logic Output  
- Event Capture Input  
- Timer Interrupt  
UART Serial  
- RS-232, RS-422 & RS-485  
- Rx & Tx Interrupts  
SPI & I<sup>2</sup>C Serial  
ADC  
EEPROM  
Flash Self Programming

Prerequisite: CS 47 and CS 49C or Instructor's Consent – Student must bring laptop and buy PCB.

Check <http://www.sublogical.org/cs185c> for up to date information.